

# Stucco and Plaster



Section: 09200

## Unpunched Casing Bead with 3-1/2" Wide Flange

Product Number	Ground	Dimensions/Descriptions	Pieces Per Box
3538	3/8" (10 mm)	3-1/2" (89 mm) wide nailing flange, non-punched.	40
3550	1/2" (13 mm)		40
3558	5/8" (16 mm)		40
3575	3/4" (19 mm)		40
3578	7/8" (22 mm)		40

10' (3 m) Lengths

Add suffix "WP" to order with weep holes. Example: 3538WP



### Application:

For use with lath installations terminating the wall at the foundation, typically frame construction where walls and foundation meet. Will not rust or dent.

### Specification:

Unpunched Casing Bead shall be Plastic Components, Inc. #\_\_\_\_\_. All exterior accessories shall conform to ASTM standards D1784, C1063 and D4216. All products shall be third party tested to meet ASTM standard D4216 and be Canadian Code Compliant. They shall be used where specified by the architect and installed per industry standards.

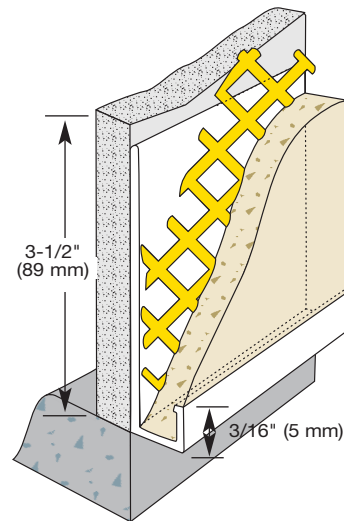

All butt joints, intersections and ends shall be caulked at the time of installation using an elastomeric sealant, such as Plastic Components' Ultra-Tech™ (PC-ULTW).

800.327.7077 ■ Fax 305.887.2452  
www.plasticcomponents.com