

Exterior Insulated Finishes



Section: 07240

EIFS Exterior Aesthetic Channel Reveal

Product Number	Dimension A	Dimension B	Pieces Per Box
2228	3/8" (10 mm)	1/2" min. (13 mm)	30
2225	1/2" (13 mm)		30
2229	5/8" (16 mm)		35
2227	3/4" (19 mm)		35
2226	1" (25 mm)		35
2235	1-1/2" (38 mm)	Large and small holes in hole pattern on flange.	30
2236	2" (51 mm)		30
2237	3" (76 mm)	No holes in flange.	20
2239	4" (102 mm)	No holes in flange.	20

10' (3 m) Lengths

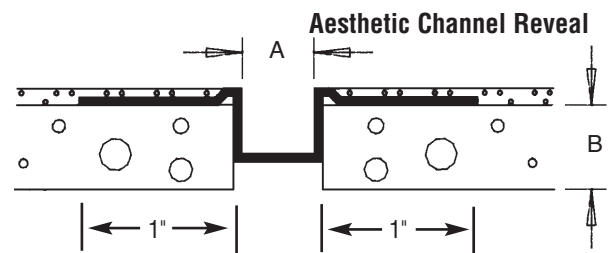
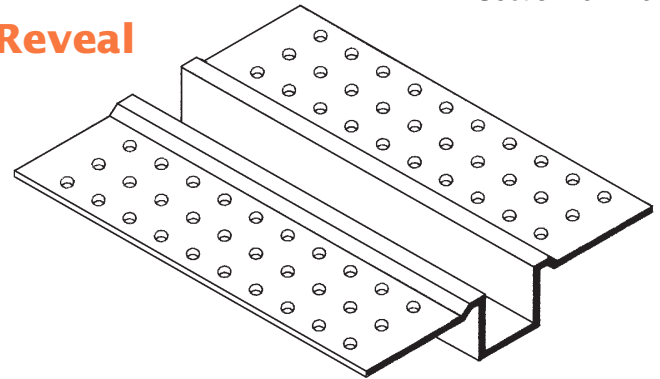

F Series Aesthetic Channel Reveal

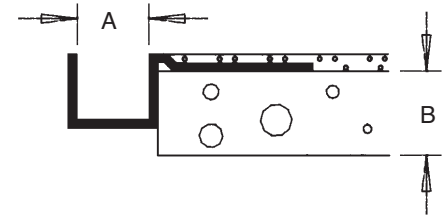

Aesthetic F Reveal also available, please contact Customer Service at (800) 327-7077

Application:

Made for exterior use in EIFS systems. The EPS board should be routed and surface mounted reveal is then inserted into channel. Wide perforated surface mounted flanges assure positive bonding of base coat to EPS and 1/8" (3 mm) stops assure proper base and finish thickness.

Specification:

Exterior Channel Reveal will be Plastic Components, Inc. #_____. All exterior accessories shall conform to ASTM standards D1784, C1063 and D4216. All products shall be third party tested to meet ASTM standard D4216 and be Canadian Code Compliant. They shall be used where specified by the architect and installed per industry standards.



The base coat mesh should be lapped over the top of the perforated flanges and across all butt joints.



800.327.7077 ■ Fax 305.887.2452
www.plasticcomponents.com