

Section: 07240

## STARTER TRAC® with Weep Holes

Product Number	Dimension A	Pieces Per Box
STWP-50	1/2" (13 mm)	35
STWP-58	5/8" (16 mm)	35
STWP-75	3/4" (19 mm)	30
STWP-78	7/8" (22 mm)	30
STWP-1	1" (25 mm)	25
STWP-125	1-1/4" (32 mm)	20
STWP-15	1-1/2" (38 mm)	20
STWP-158	1-5/8" (41 mm)	15
STWP-175	1-3/4" (44 mm)	15
STWP-2	2" (51 mm)	15
STWP-225	2-1/4" (57 mm)	15
STWP-25	2-1/2" (64 mm)	15
STWP-275	2-3/4" (70 mm)	10
STWP-3	3" (76 mm)	10
STWP-35	3-1/2" (89 mm)	10
STWP-4	4" (102 mm)	10

10' (3 m) Lengths

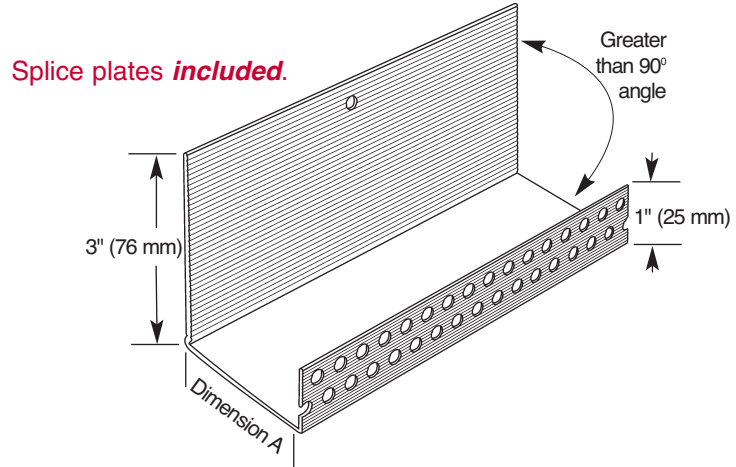

**Application:** Can be used as a STARTER TRAC® at the base of a wall or an EIFS Casing Bead around window and door openings. Face return flange is 1" (25 mm) with striations which provide a strong physical bond for the base coat and perforations for bonding the base to the substrate. Available with weep holes. Ideal for use where finished edge is exposed. 3" (76 mm) wide nailing flange also has striations for extra bonding.

**Specification:** STARTER TRAC® /EIFS Casing Bead will be Plastic Components, Inc. #\_\_\_\_\_. All exterior accessories shall conform to ASTM All products shall be third party tested to meet ASTM standard D4216 and be Canadian Code Compliant. They shall be used where specified by the architect and installed per industry standards.

