

Stucco and Plaster

Section: 09200

Unpunched Casing Bead with 3-1/2" Wide Flange (Weeped or Unweeped)

**NEW
Size!**

Product Number	Ground	Dimensions/Descriptions	Pieces Per Box
3550	1/2" (13 mm)	3-1/2" (89 mm) wide nailing flange, non-punched.	40
3558	5/8" (16 mm)		40
3575	3/4" (19 mm)		40
3578	7/8" (22 mm)		40
35100	1" (25 mm)		40

10' (3 m) Lengths

Add suffix "WP" to order with weep holes. Example: 3550WP



Application:

For use with lath installations terminating the wall at the foundation, typically frame construction where walls and foundation meet. Will not rust or dent.

Specification:

Unpunched Casing Bead shall be Plastic Components, Inc. #_____. All exterior trim shall be of PVC material that meets ASTM D1784, C926, C1063, C1861, and D4216, shall be third party tested and be Canadian code compliant. They shall be used where specified by the design authority and installed per industry standards.

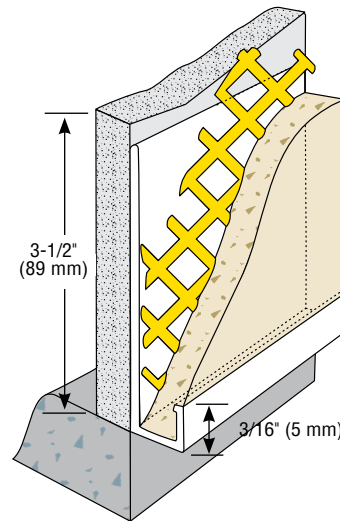

All butt joints, intersections and ends shall be caulked at the time of installation using an elastomeric sealant, such as Plastic Components' Ultra-Tech™ (PC-ULTW).