

Direct Applied Finishes

Section: 07240

CB DEFS Casing Bead

Product Number	Dimension A	Pieces Per Box
CB-50-16	1/2" (13 mm)	60
CB-58-16	5/8" (16 mm)	60

Add suffix "WP" to order with weep holes.
 Example: CBWP-50-16
 10' (3 m) Lengths

Application:

Serves as a protective edge for sheathing material at areas of termination. Eliminates the need to back wrap; provides a clean starting detail. Excellent caulk and paint adhesion, holes on return flange allow for base coat to bond to surface of substrate.

Specification:

Casing Bead/STARTER TRAC shall be Plastic Components, Inc. #_____. All exterior accessories shall conform to ASTM standards D1784, C1063 and D4216. They shall be used where specified by the architect and installed per industry standards.

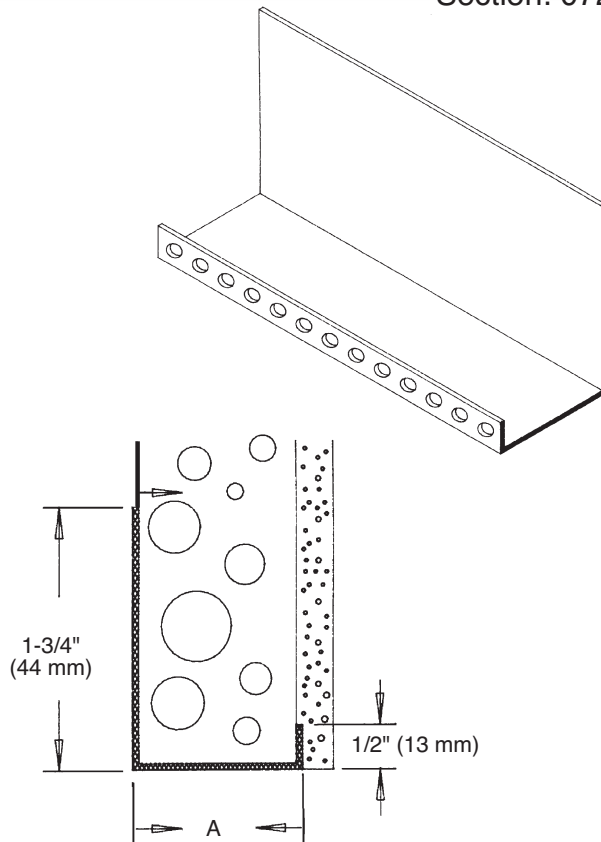

JW138 Casing Bead

Product Number	Dimensions/Descriptions	Pieces Per Box
JW138	Nailing flange 3-1/2" (89 mm), return face flange 1/4" (6 mm) and horizontal shelf 1-3/8" (38 mm)	40

Application:

A Starter Trac designed for use with 1" (25 mm) insulation board and 3/8" (10 mm) thick one-coat stucco. UBC code approved with a 3-1/2" (89 mm) nailing flange and weep holes added to the horizontal shelf allow for any unwanted moisture to escape.

Specification:

Starter Trac shall be Plastic Components, Inc. #_____. All exterior accessories shall be of PVC material conforming to ASTM standards D1784, C1063 and D4216. They shall be used where specified by the architect and installed per industry standards.

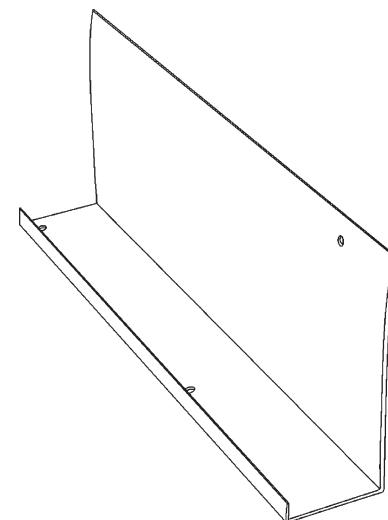

The base coat mesh should be lapped over the top of the perforated flanges and across all butt joints.

Caulk all butt joints, intersections and ends.



800.327.7077
 www.plasticcomponents.com