

# CI/EIFS/Hard Coat

Section: 07240

## Starter TRAC™ Drip Edge

Product Number	Dimension A	Pieces per Box
STDE-50	1/2" (13 mm)	35
STDE-58	5/8" (16 mm)	35
STDE-75	3/4" (19 mm)	30
STDE-78	7/8" (22 mm)	30
STDE-1	1" (25 mm)	25
STDE-125	1-1/4" (32 mm)	20
STDE-15	1-1/2" (38 mm)	20
STDE-175	1-3/4" (44 mm)	15
STDE-2	2" (51 mm)	15
STDE-225	2-1/4" (57 mm)	15
STDE-25	2-1/2" (64 mm)	15
STDE-275	2-3/4" (70 mm)	10
STDE-3	3" (76 mm)	10
STDE-35	3-1/2" (89 mm)	10
STDE-4	4" (102 mm)	10

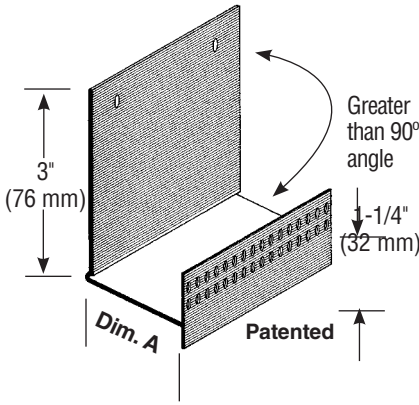
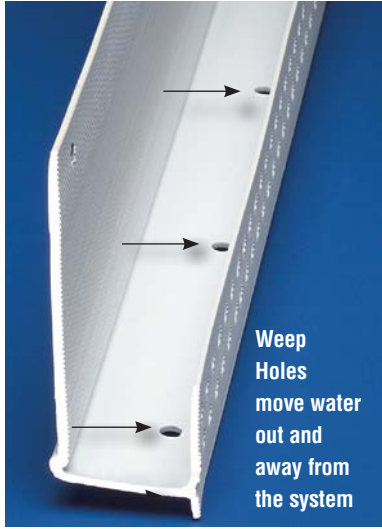

Splice plates available upon request

### Application:

STARTER TRAC® with drip edge. Face return flange 1-1/4" (32 mm) with striations which provide a strong physical bond for the base coat and perforations for bonding of the base to the substrate. Extra wide 3" (76 mm) nailing flange has striations on inside face to aid bonding of foam board to nailing flange. Base shelf has weep holes 3" (76 mm) o.c. to allow migration of water from system.

### Specifications:

STDE STARTER TRAC®/Casing Bead shall be Plastic Components, Inc. # \_\_\_\_\_. All exterior accessories shall meet ASTM standards D1784, C1063 and D4216, shall be third party tested and Canadian Code Compliant. They shall be used where specified by the design authority and installed per industry standards.

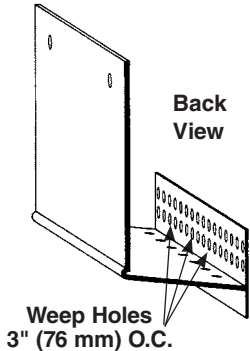

The base coat mesh should be lapped over the top of the perforated flanges and across all butt joints.

