

# Direct Applied Finishes

Section: 07240

## STARTER TRAC™ Drip Edge

Product Number	Description	Dimension A	Pieces per Box
STDE-50	STARTER TRAC with drip edge. Striations on front return, and perforations ensure positive physical bond of the base coat to the foam board. Extra wide 3" (76 mm) nailing flange.	1/2" (13 mm)	35
STDE-58	Base shelf has weep holes 3" (76 mm) o.c. to allow water to migrate from the system.	5/8" (16 mm)	35

10' (3 m) Lengths

Splice plates available upon request.

### Application:

STARTER TRAC® with drip edge. Striations on front return and perforations ensure positive physical bond of the base coat to the foam board. Extra wide 3" (76 mm) nailing flange. Base shelf has weep holes 3" (76 mm) o.c. to allow water to migrate from the system.

### Specifications:

STARTER TRAC® Drip Edge shall be Plastic Components Inc. # \_\_\_\_\_. All exterior accessories shall conform to ASTM standards D1784, C1063 and D4216. They shall be used where specified by the design authority and installed per industry standards.

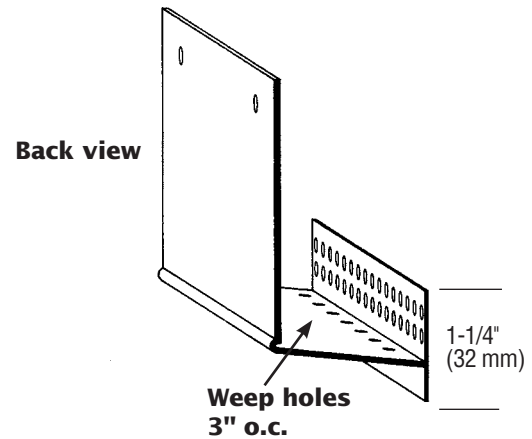
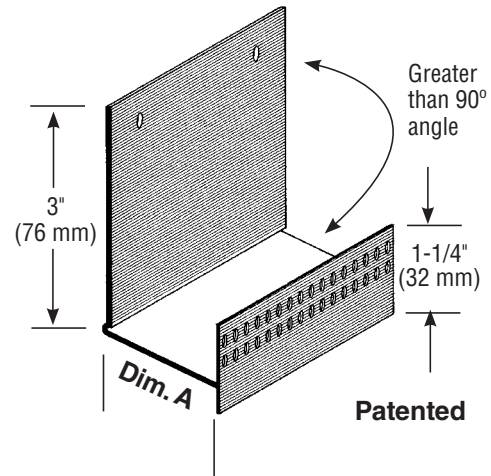

The base coat mesh should be lapped over the top of the perforated flanges and across all butt joints.



305.885.0561 ■ 800.327.7077  
www.plasticcomponents.com