

CI/EIFS/Hard Coat

Section: 07240

Corner Bead

**NEW
Larger
Holes!**

Product Number	Dimension/Description	Pieces Per Box
2209	1-5/8" x 1-5/8" (41 mm x 41 mm) wide grooved flanges with large holes.	100

10' (3 m) Lengths

Application:

Designed with wide flanges to ensure straight and rust-free corners while providing high-impact resistant corners. Flange has striations and perforations to ensure a positive bond of the base to the flange and the surface of the sheathing material.

Specification:

Corner bead will be Plastic Components, Inc. #_____. All exterior accessories shall meet ASTM standards D1784, C1063, C1861 and D4216, shall be third party tested and Canadian Code compliant. They shall be used where specified by the design authority and installed per industry standards.

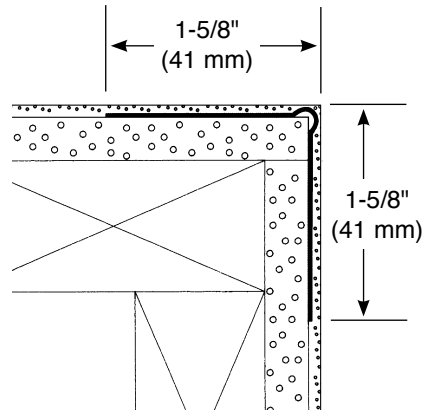

PLASTIC PC™
COMPONENTS inc.

The base coat mesh should be lapped over the top of the perforated flanges and across all butt joints.

800.327.7077 ■ Fax 305.887.2452
www.plasticcomponents.com