

# CI/EIFS/Hard Coat

Section: 07240

## Raised Bridge Joint

Product Number	Dimension/Description	Pieces Per Box
1609	An alternative to removing foam around window and installing backer rod and caulk.	50

10' (3 m) Lengths

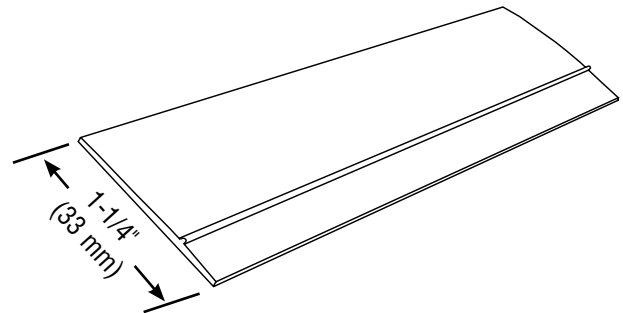
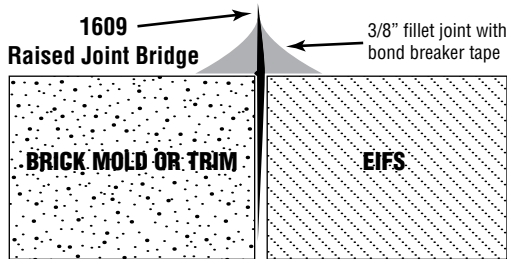

### Application:

An alternative to removing foam around window and installing backer rod and caulk.

### Specification:

Raised Bridge Joint will be Plastic Components, Inc. #\_\_\_\_\_. All exterior accessories shall meet ASTM standards D1784, C1063, C1861 and D4216, shall be third party tested and Canadian Code compliant. They shall be used where specified by the design authority and installed per industry standards.



The base coat mesh should be lapped over the top of the perforated flanges and across all butt joints.

800.327.7077 ■ Fax 305.887.2452  
[www.plasticcomponents.com](http://www.plasticcomponents.com)