

Plastic Components' "V" control joint is designed to relieve stress caused by expansion and contraction within a vertical or horizontal direct applied system.

Removable tape in the deep groove "V" keeps the "V" clean during installation.

Sheathing board installs between the nailing flange and perforated "wings" which have stops to ensure clean, straight lines during the application of ground coat and finish.

- Perforations assure positive bond of ground coat to substrate
- Non-rusting PVC
- UV rated for long outdoor life
- Excellent paint adhesion
- Conforms to ASTM standards D1784, C1063, D4216



### PL0293

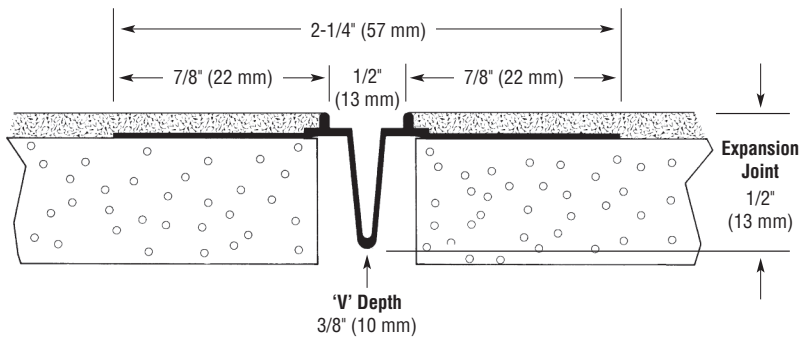

Place control joint at 144 sq. ft. intervals (13.5 sq. meters)

### PL0293-75

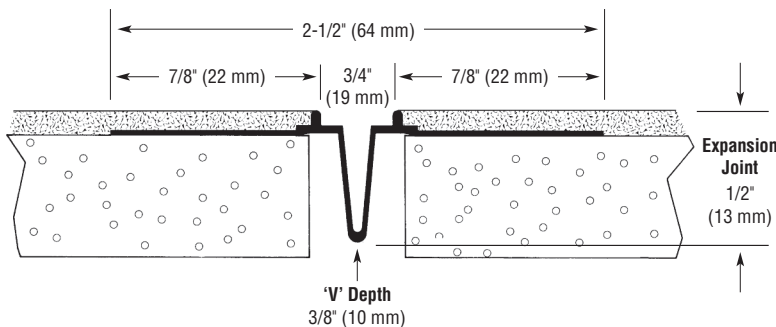

Product Number	Dimension/Description	Pieces per Box
PL0293	Inverted 1/2" (13 mm) expansion joint.	60
PL0293-75	Inverted 3/4" (19 mm) expansion joint.	60
3/8" (10 mm) 'V' depth 1/16" (2 mm) finish top with removable tape 10 ft (3 m) Lengths		

